

Ceiling and Pipe Hangers

for Vibration Isolation and Structure-Borne Noise Reduction



- Load capacity up to 8.6 kN
Vertical natural frequency 2.6 Hz (minimum)

- Mode of Function
The usage of G+H ceiling and pipe hangers reduces vibrations and structure-borne noise in buildings.

- Advantages
 - Steel screw pressure springs acc. to DIN EN 13906 block fixed to absorb overloads (e.g. during erection)
 - Effective vibration isolation and structure-borne noise reduction, even at low frequencies

- Effective structure-borne noise control through integrated structure-borne-noise-reducing insert
- Simple installation
- Because of the open construction, the operation is always controllable

- Construction
Types D1 - D2 galvanised,
Types D3 - D7 undercoat

Technical Data, Dimensions, Weights

Typ	Model	Load Capacity F_{zul} [kN]	Spring Constant vertical C_v [N/mm]	Natural frequency vertical ² f_0 [Hz]	Heighte		Dimensions					Weight [kg]
					Un-loaded ¹ H_A [mm]	loaded ² H_B [mm]	L [mm]	A x B [mm]	d [mm]	s [mm]	G [mm]	
D1	A	0.16	10	3.9	20	36	85	40 x 35	5	10	10	0.11
	B				22	38					M 6	
D2	A	0.26	16	3.9	19	35	124	54 x 45	8	10	10	0.12
	B				21	37					M 6	
D3	A	0.50	15	2.7	24	57	124	54 x 45	8	10	12	0.37
	B				28	61					M 8	0.38
D4	A	1.30	63	3.5	24	45	124	54 x 45	8	10	12	0.45
	B				28	49					M 8	0.46
D5	B	3.40	91	2.6	34	71	220	100 x 100	11,5	20	M 12	2.61
D6	B	6.20	192	2.8		66						2.85
D7	B	8.60	328	3.1		60						3.19

¹ other lengths upon request

² at maximum load capacity

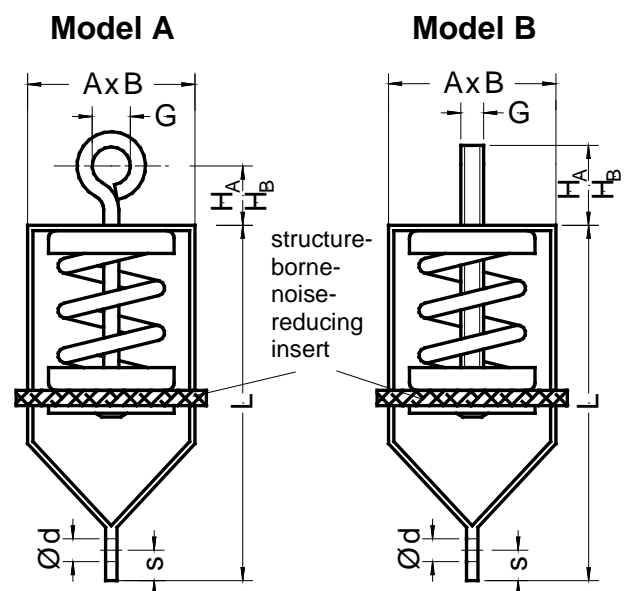
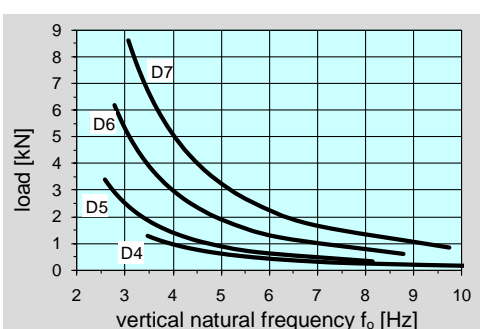
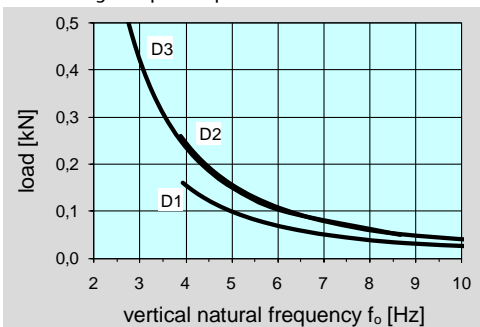

Wall- and Ceiling spring stripe

Weight: 0.07 kg

With or without sound-absorbing coating to improve the structure-borne sound insulation

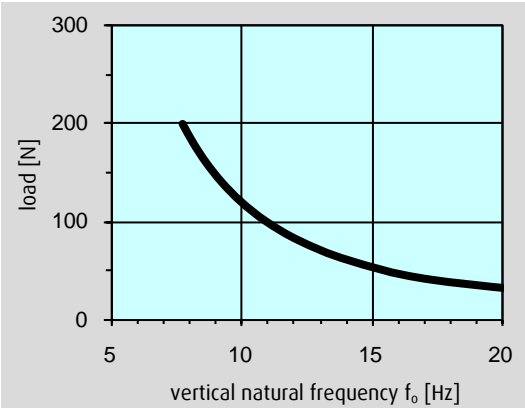
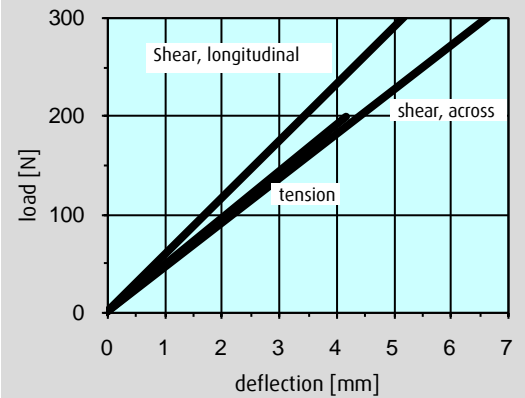
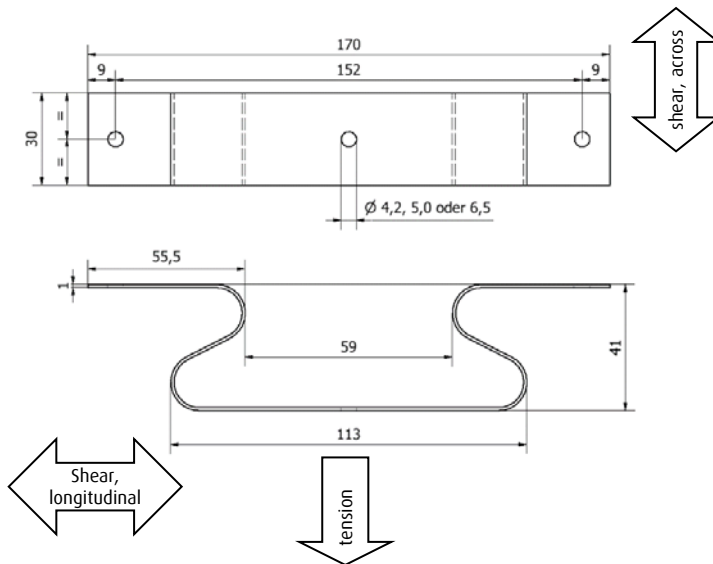

Elasto®-bell element

Weight: 0.11 kg

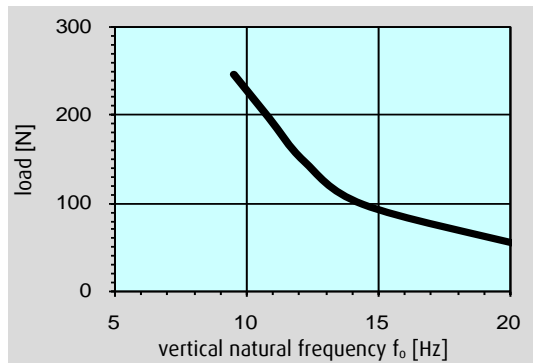
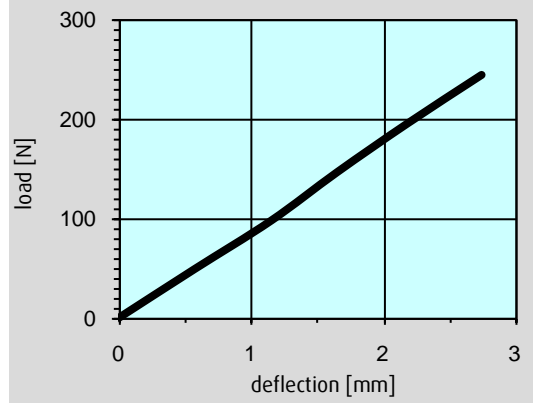
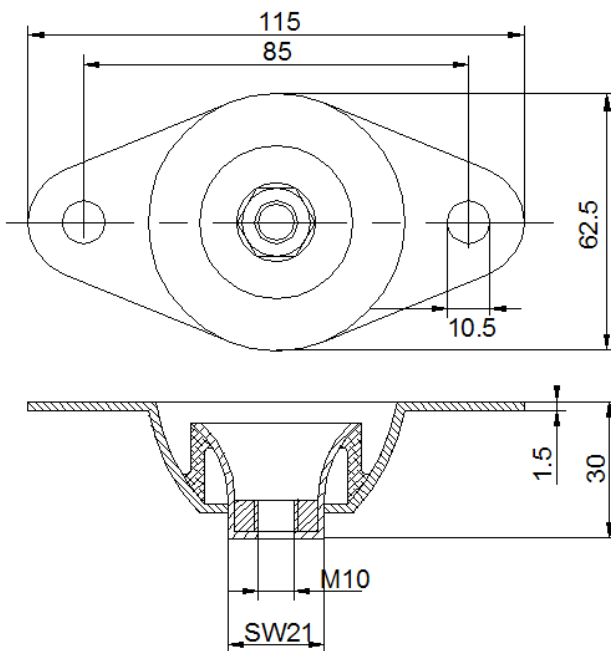

The data given in this product information corresponds to the state of the art and our know-how and is subject to alterations. Guarantees are only valid on individual contracts when executed by G+H Schallschutz.