

Approval body for construction products
and types of construction

Bautechnisches Prüfamt

An institution established by the Federal and
Laender Governments



European Technical Assessment

ETA-10/0013
of 15 November 2018

English translation prepared by DIBt - Original version in German language

General Part

Technical Assessment Body issuing the
European Technical Assessment:

Deutsches Institut für Bautechnik

Trade name of the construction product

PYROSTAT-UNI

Product family
to which the construction product belongs

Intumescent Product used for penetration seals

Manufacturer

G+H Isolierung GmbH
Leuschner Straße 2
97084 Würzburg
DEUTSCHLAND

Manufacturing plant

G+H Isolierung GmbH
Leuschner Straße 2
97084 Würzburg
DEUTSCHLAND

This European Technical Assessment
contains

11 pages including 7 annexes which form an integral part
of this assessment

This European Technical Assessment is
issued in accordance with Regulation (EU)
No 305/2011, on the basis of

EAD 350454-00-1104

This version replaces

ETA-10/0013 issued on 19 June 2013

The European Technical Assessment is issued by the Technical Assessment Body in its official language. Translations of this European Technical Assessment in other languages shall fully correspond to the original issued document and shall be identified as such.

Communication of this European Technical Assessment, including transmission by electronic means, shall be in full. However, partial reproduction may only be made with the written consent of the issuing Technical Assessment Body. Any partial reproduction shall be identified as such.

This European Technical Assessment may be withdrawn by the issuing Technical Assessment Body, in particular pursuant to information by the Commission in accordance with Article 25(3) of Regulation (EU) No 305/2011.

Specific part

1 Technical description of the product

The construction product "PYROSTAT-UNI" is a fire protection wrap which is a cutout from an intumescent mat.

The fire protection wrap consists of a flexible, anthracite-coloured mat with micaceous speckles, which expands under heat exposure.

A detailed technical description of the fire safety related performance criteria of the construction product is given in Annex 1.

NOTE:

The characteristics listed are suitable both for identifying the construction product as well as for performing the manufacturer's factory production control.

2 Specification of the intended use in accordance with the applicable European Assessment Document

The construction product "PYROSTAT-UNI" is used as a component in pipe penetration seals.

Pipe penetration seals are used to seal openings in fire-resistant walls or floors, which are penetrated by pipes. Their aim is to preserve the walls' or floors' fire resistance in the area of the penetrations. The construction product "PYROSTAT-UNI" is intended for use as a wrap for pipes made of steel, stainless steel, cast iron or copper. In the event of fire, the intumescent effect of the wrap helps prevent the passage of heat and the spread of fire in the area of the pipes.

This ETA has served to verify the resistance to fire of pipe penetration seals containing the construction product "PYROSTAT-UNI". The pipe penetration seals also comprised pipe insulation material and, in some cases, a metal sheet collar as well as a seal between the penetrating pipe and the circular edge of the surrounding building component.

More detailed information and data on the verified penetration seals are given in Annexes 3 to 7.

The construction product "PYROSTAT-UNI" may be used in penetration seals of use category Z₂ (dry internal conditions without frost (relative humidity between 50 % and 85 % and temperatures between +5 °C and 35 °C ± 5 °C) provided that the other components of the penetration seal, which are not the subject of this ETA, meet the durability requirements. The resistance to fire of the penetration seals shall be verified on a case-by case basis.

The performance data given in Section 3 relates exclusively to these penetration seals (e.g. with respect to the design and arrangement of the penetration seal components and the type and position of the services).

3 Performance of the product and references to the methods used for its assessment

3.1 Intended use: use in penetration seals

3.2 Safety in case of fire (BWR 2)

Essential characteristic	Performance
Reaction to fire of the fire protection wrap	Class E in accordance with EN 13501-1
Resistance to fire of a penetration seal containing the construction product	The resistance to fire depends on how the penetration seal is designed and installed and on the other components forming the penetration seal. More details on the tested penetration seals and the related fire resistance classes are given in Annexes 1 to 7.

4 Assessment and verification of constancy of performance (AVCP) system applied, with reference to its legal base

In accordance with European Assessment Document (EAD) no. 350454-00-1104, the following legal base shall apply: 1999/454/EC.

The system to be applied is: system 1.

5 Technical details necessary for the implementation of the AVCP system, as provided for in the applicable EAD

Technical details necessary for the implementation of the AVCP system are laid down in the control plan deposited with Deutsches Institut für Bautechnik.

Issued in Berlin on 15 November 2018 by Deutsches Institut für Bautechnik

Prof. Gutner Hoppe
Head of Department

beglaubigt:
Bisemeier

Properties and performances criteria of the construction product "PYROSTAT-UNI"

Component	Property	Characteristic value with tolerances
"PYROSTAT-UNI" Wrap made of an intumescent building material ¹	Classification of fire behavior acc. to EN 13501-1	E
	Nominal thickness	1,0 mm to 1,4 mm; thickness tolerances $\pm 10\%$
	Weight per unit area	1,2 kg/m ² $\pm 10\%$
	Loss mass on heating	40,0 % bis 50 % (tested on 450 °C over 30 minutes)
	Expansion ratio	10,0 to 18,0 (tested on 450 °C over 30 minutes with applied weight with samples of a thickness of $\sim 1,2$) ²
	Expansion pressure	0,45 N/mm ² to 1,10 N/mm ² (tested on 300 °C, method A) ²

The properties listed can be used both for the identification of the construction product and for the implementation of the factory production control of the manufacturer.

Implementation details for the factory production control are included in the inspection plan.

¹ The composition of the materials is deposited at DIBt.

² Implementation Details of the test method are deposited at DIBt.

PYROSTAT-UNI	Annex 1
Description of the construction product, properties and performances	

Description of the additional components of the tested sealings

FEF Kaiflex KK	Declaration of performance DoP KK 17022015001 of 04.02.2016
AEROFLEX KKS	Declaration of performance Nr. 12-CPR-2015-12-08 (de) of 08.12.2015
K-Flex Eco	Declaration of performance No. 0507010211-CPR-13 of 03.07.2014
Zinc-plated sheet steel cylinder	Zinc-plated sheet steel (material number DX51D) acc. to EN 10346 Thickness: 0,8 mm
Gypsum filling compound	Classification of fire behavior: Class A1 according to the commission decision 96/603/EC (in the amended version)

Performances of tested penetration seals, comprising the construction product "PYROSTAT-UNI"

	Essential requirement	Test method	Construction of the sample	Performance acc. to EN 13501-2
1	Resistance to fire	EN 1366-3	200 mm thick rigid wall; design and layout of the penetration seal acc. to Annex 3*	see Annex 3
2	Resistance to fire	EN 1366-3	100 mm thick flexible wall; design and layout of the penetration seal acc. to Annex 4*	see Annex 4
3	Resistance to fire	EN 1366-3	150 mm thick rigid floor; design and layout of the penetration seal acc. to Annex 5*	see Annex 5
4	Resistance to fire	EN 1366-3	100 mm thick flexible wall; design and layout of the penetration seal acc. to Annex 6*	see Annex 6
5	Resistance to fire	EN 1366-3	100 mm thick flexible wall; design and layout of the penetration seal acc. to Annex 7*	see Annex 7

* Illustrations without guarantee for completeness

The use of the construction product "PYROSTAT-UNI" in penetration seals shall be in accordance with national requirements for planning, design and execution and in accordance with the installation instruction of the manufacturer.

The tested/ illustrated seals are only examples for the use.

PYROSTAT-UNI	Annex 2
Description of the construction product, properties and performances	

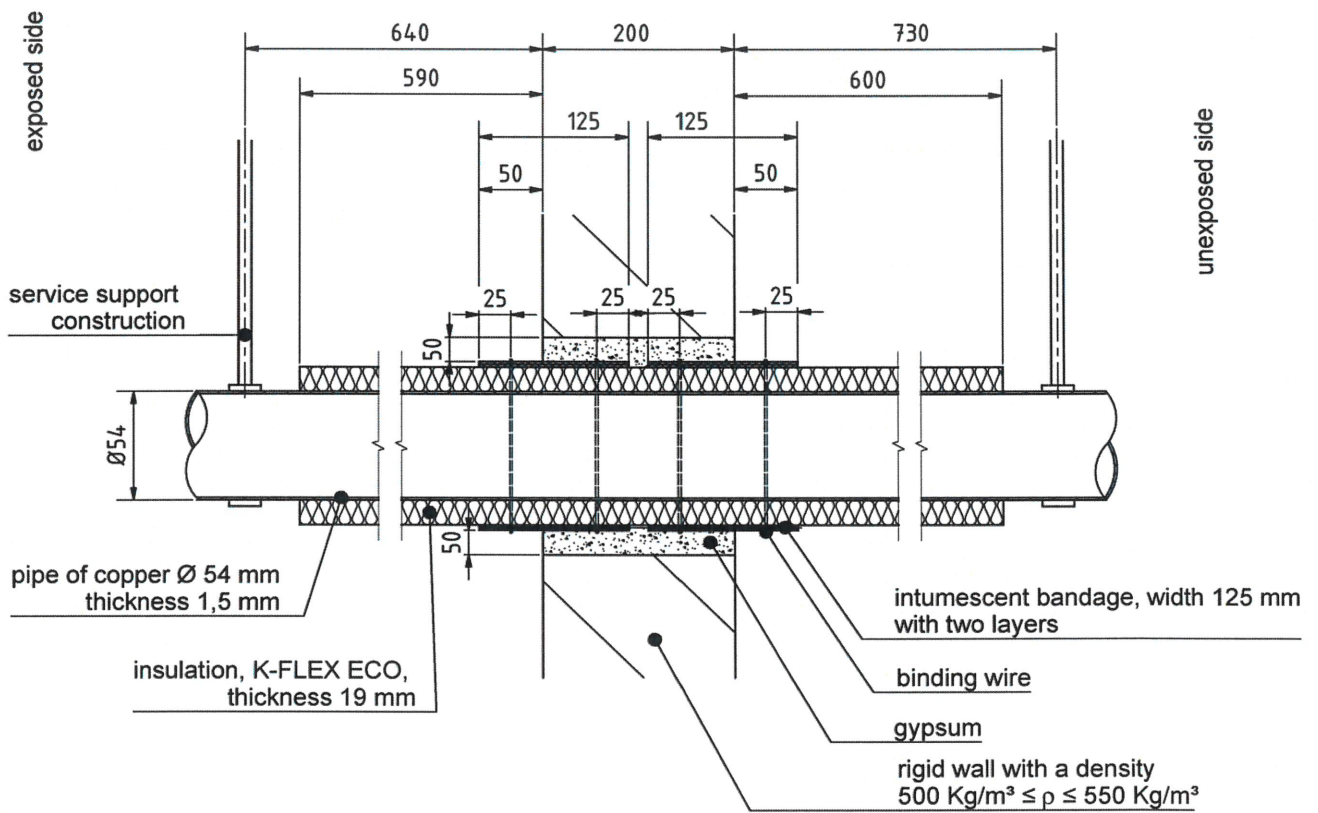
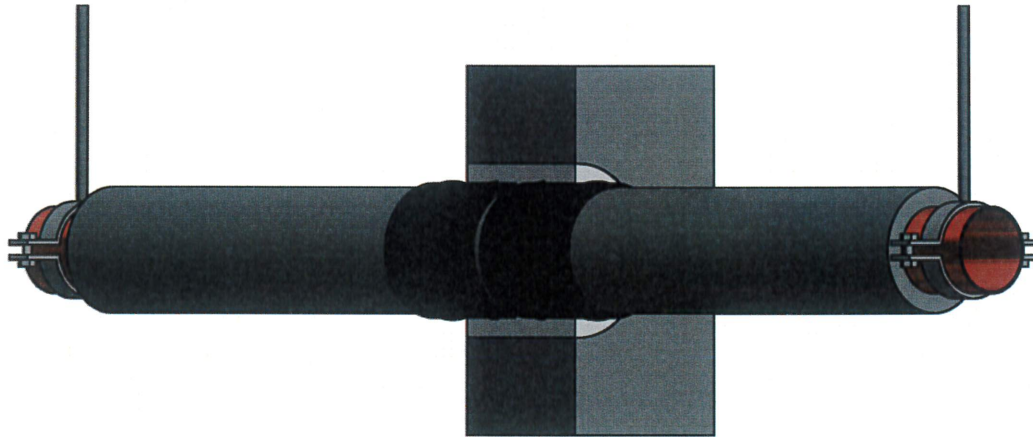

PYROSTAT-UNI

Example for use the construction product "PYROSTAT UNI" as a part of a pipe sealing,
with a fire resistance (integrity and thermal insulation) for more than 120 minutes

Annex 3

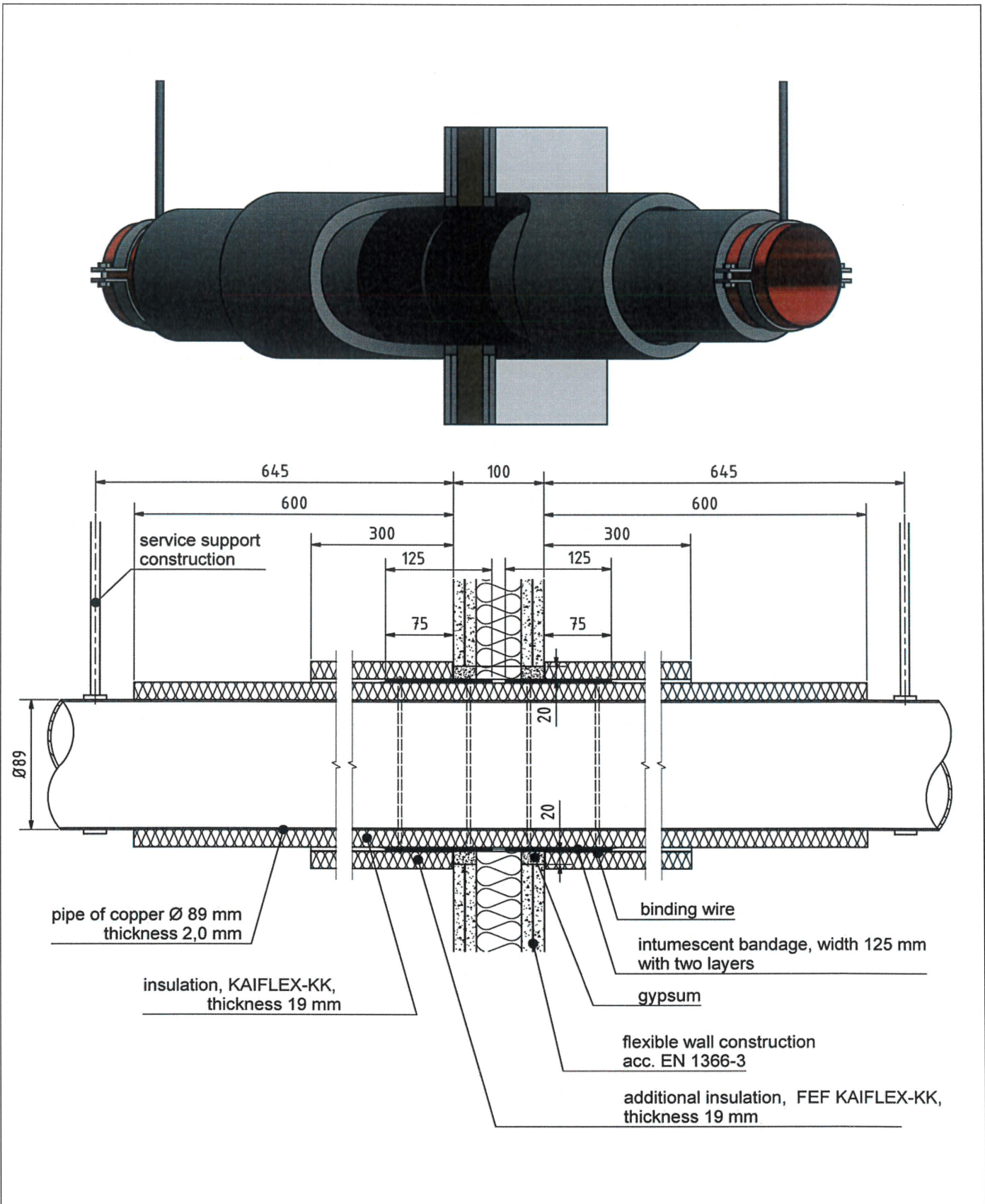

PYROSTAT-UNI

Example for use the construction product "PYROSTAT UNI" as a part of a pipe sealing, with a fire resistance (integrity and thermal insulation) for more than 120 minutes

Annex 4

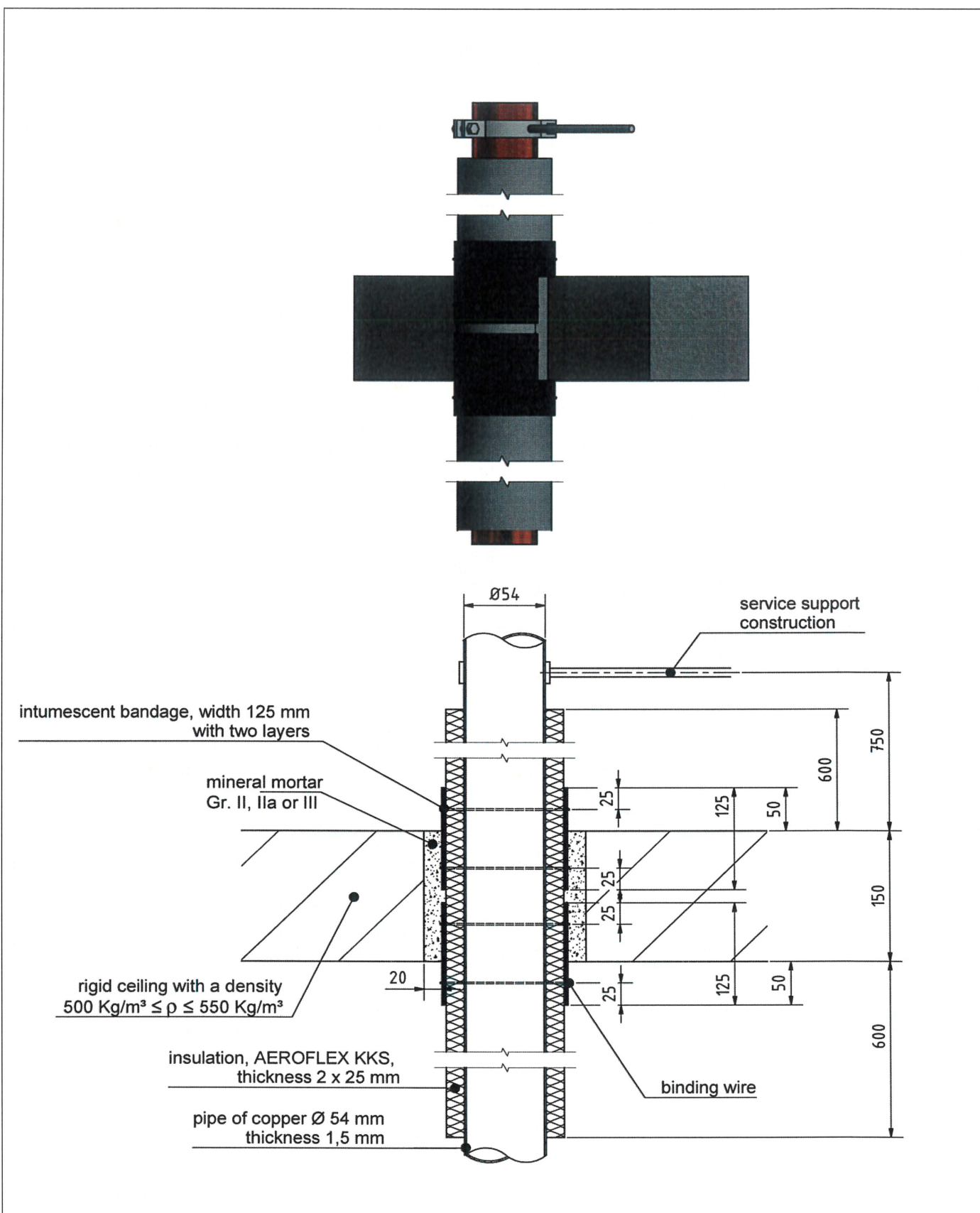

<p>PYROSTAT-UNI</p>	<p>Annex 5</p>
<p>Example for use the construction product "PYROSTAT UNI" as a part of a pipe sealing, with a fire resistance (integrity and thermal insulation) for more than 120 minutes</p>	

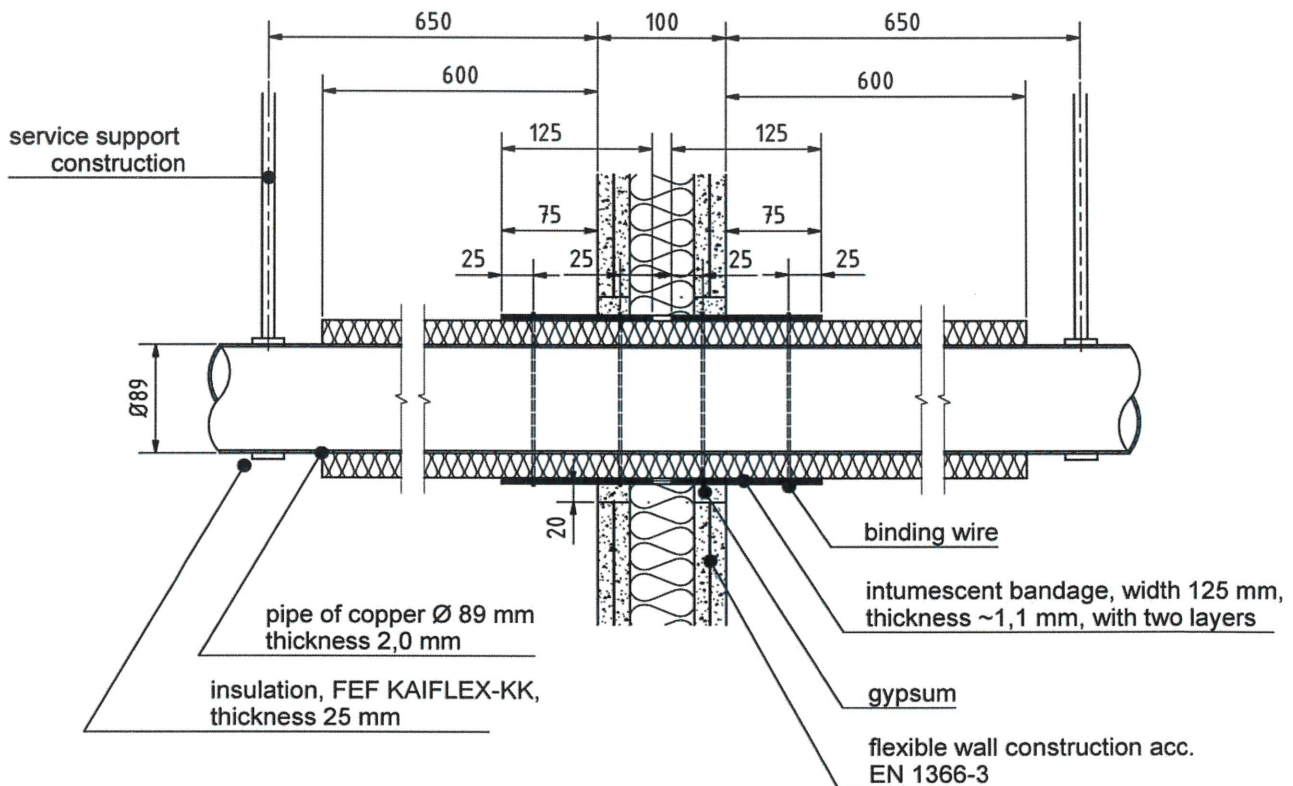
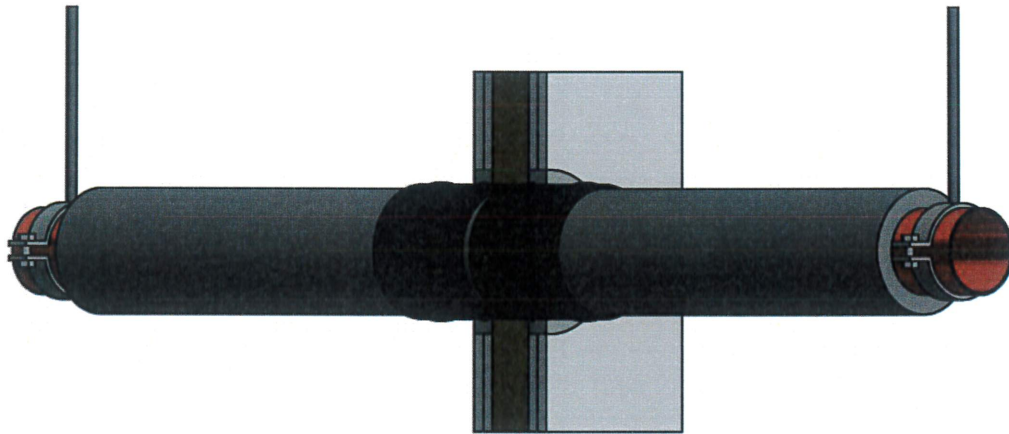

PYROSTAT-UNI

Example for use the construction product "PYROSTAT UNI" as a part of a pipe sealing,
with a fire resistance (integrity and thermal insulation) for more than 120 minutes

Annex 6

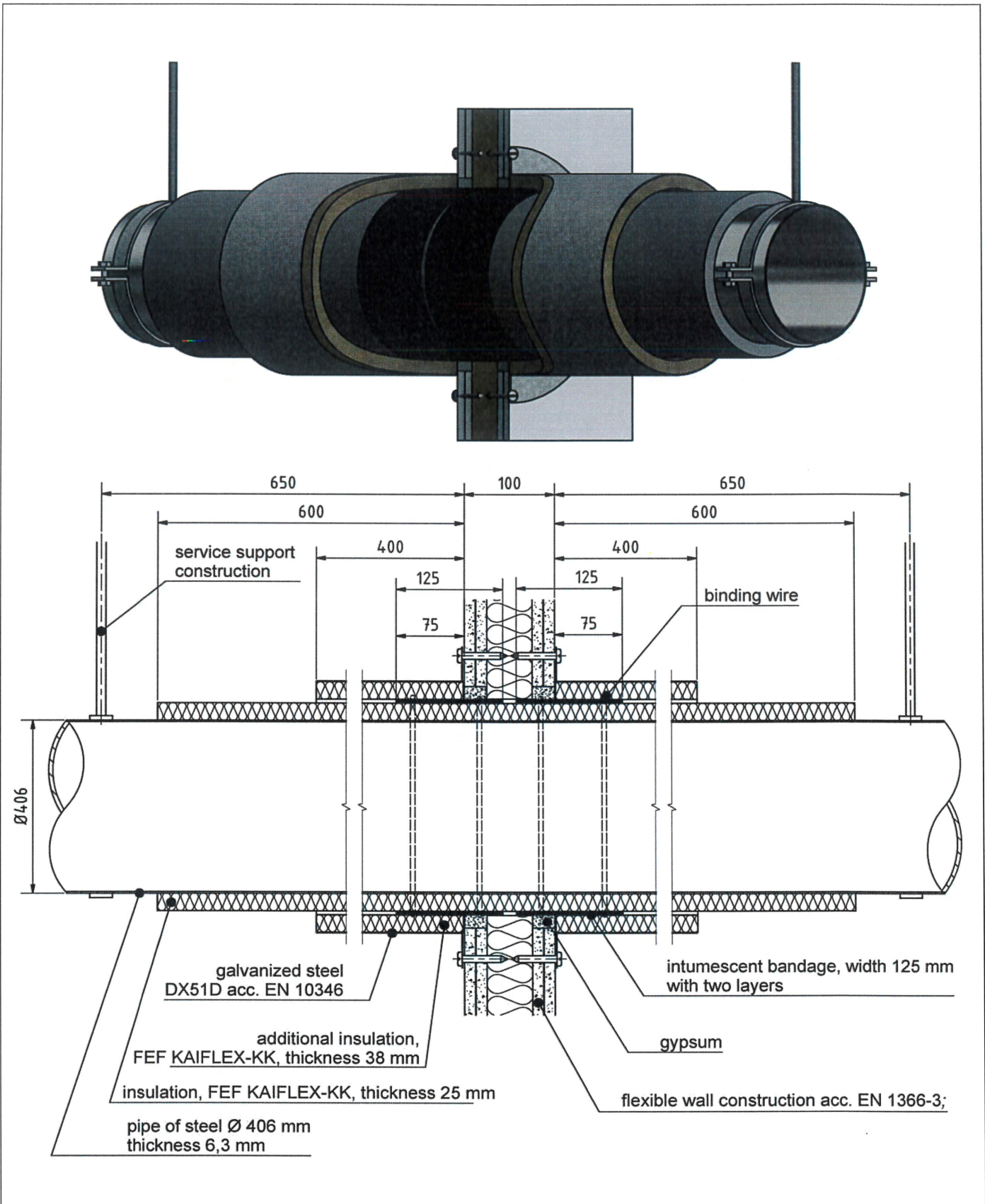

PYROSTAT-UNI

Example for use the construction product "PYROSTAT UNI" as a part of a pipe sealing, with a fire resistance (integrity and thermal insulation) for more than 60 minutes

Annex 7